



Newest DTTB Products in Japan

SET 2006 CONGRESS

24th ,August, 2006

DiBEG JAPAN

Yasuo TAKAHASHI
(Toshiba)



Japanese DTTB Market

- DTTB penetration in Japan
- Trend of Digital receiver
- DTTB market growth in Japan





Schedule of Digital Broadcasting in Japan

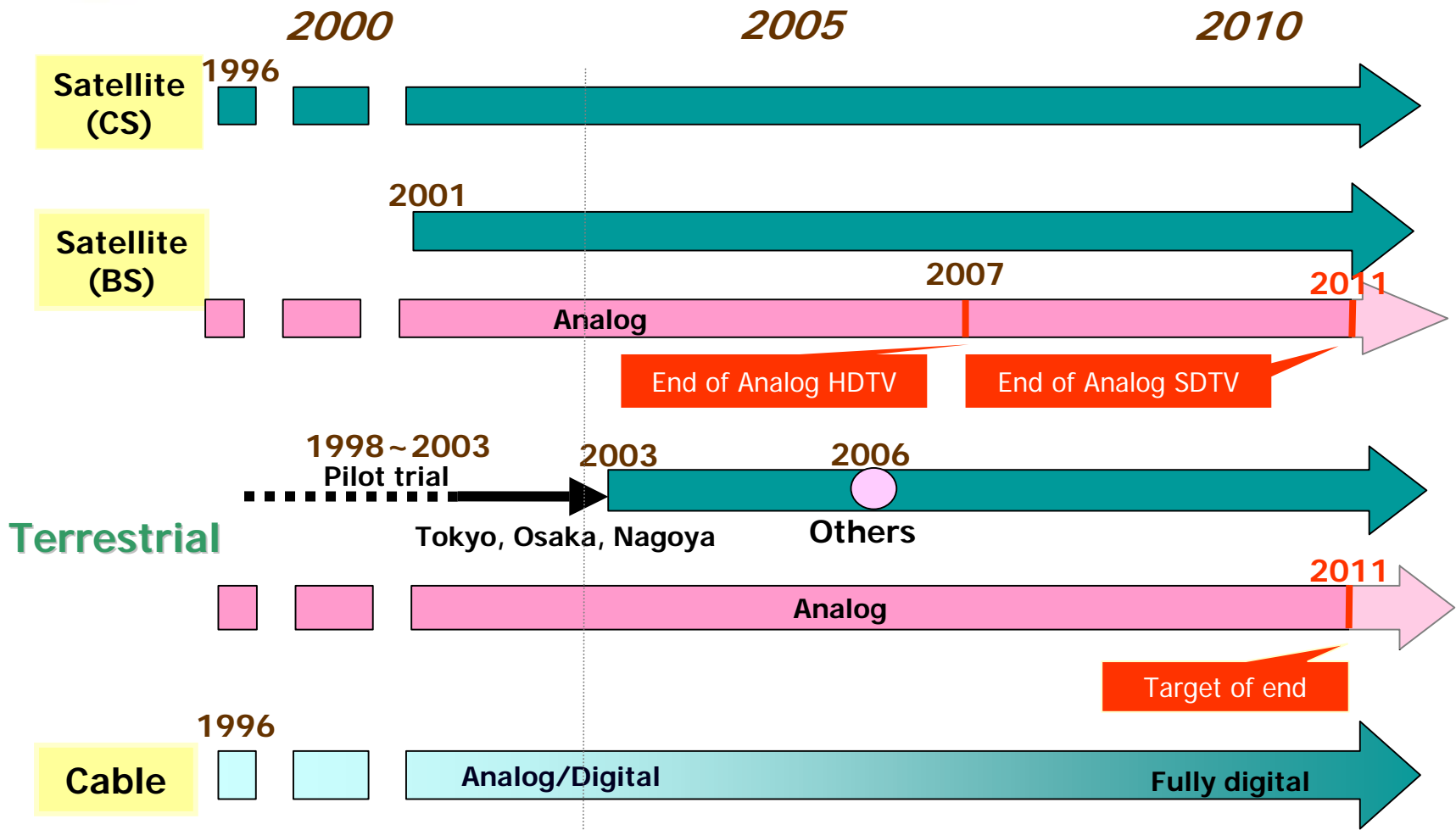

Expansion Schedule for Digital Terrestrial TV

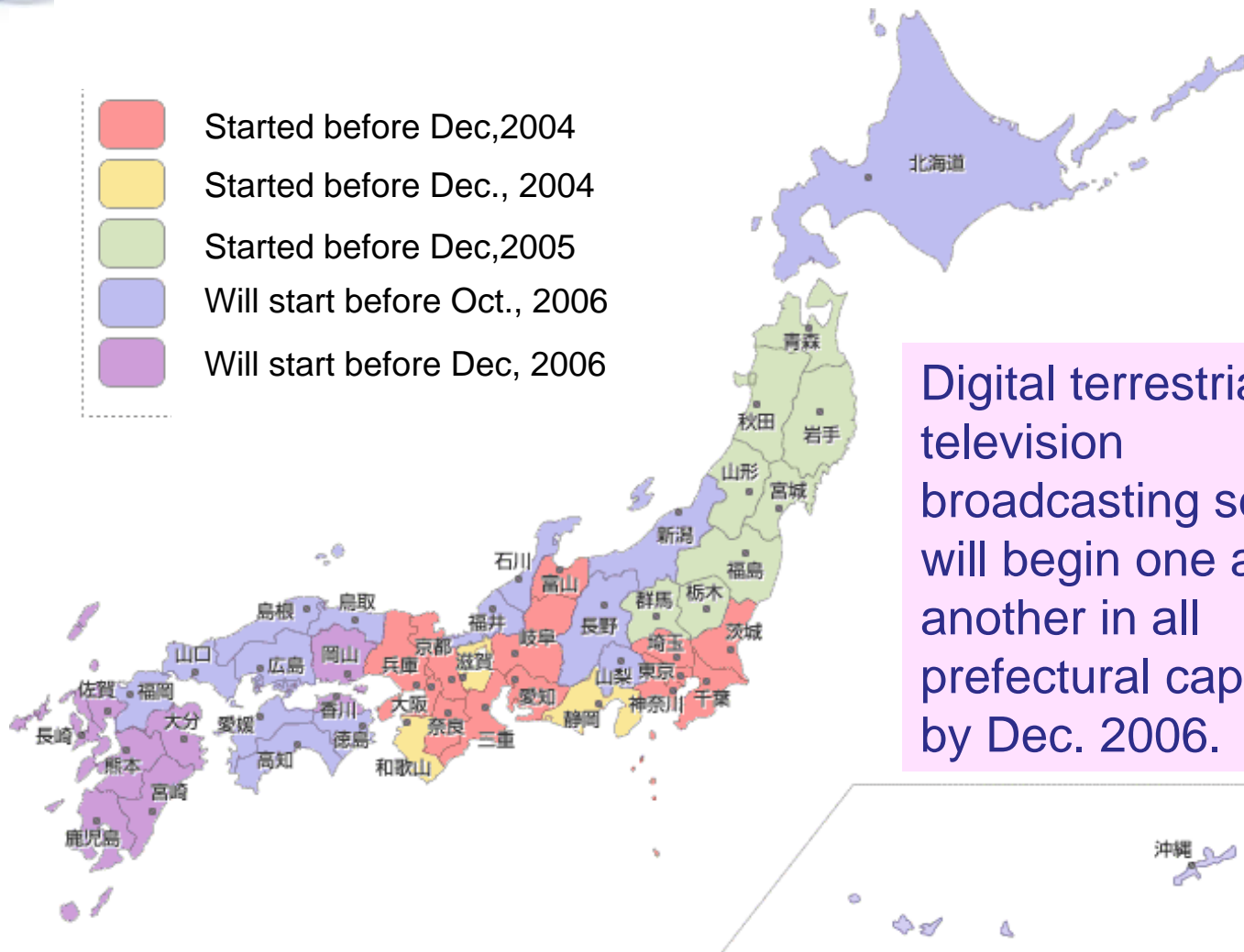

Digital terrestrial television broadcasting service will begin one after another in all prefectural capitals by Dec. 2006.



Households Coverage

- On December 1st 2003, Digital Terrestrial TV started in three metropolitan areas (Tokyo, Osaka, Nagoya)
- Households Coverage (percentage of the households which can receive DTTB) increases every year as shown below.
 - In December 2004: 18.0 million households (38%)
 - In December 2005: 28.4 million households (60%)
 - In December 2006: 38.5 million households (82%)
(DTTB is available in all the prefectural capitals)
- ✓ Industry's target is that every household has more than one DTTB receivers by 2011.

Service Model of One-segment DTTB

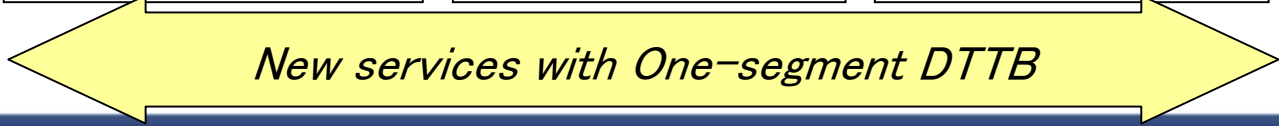
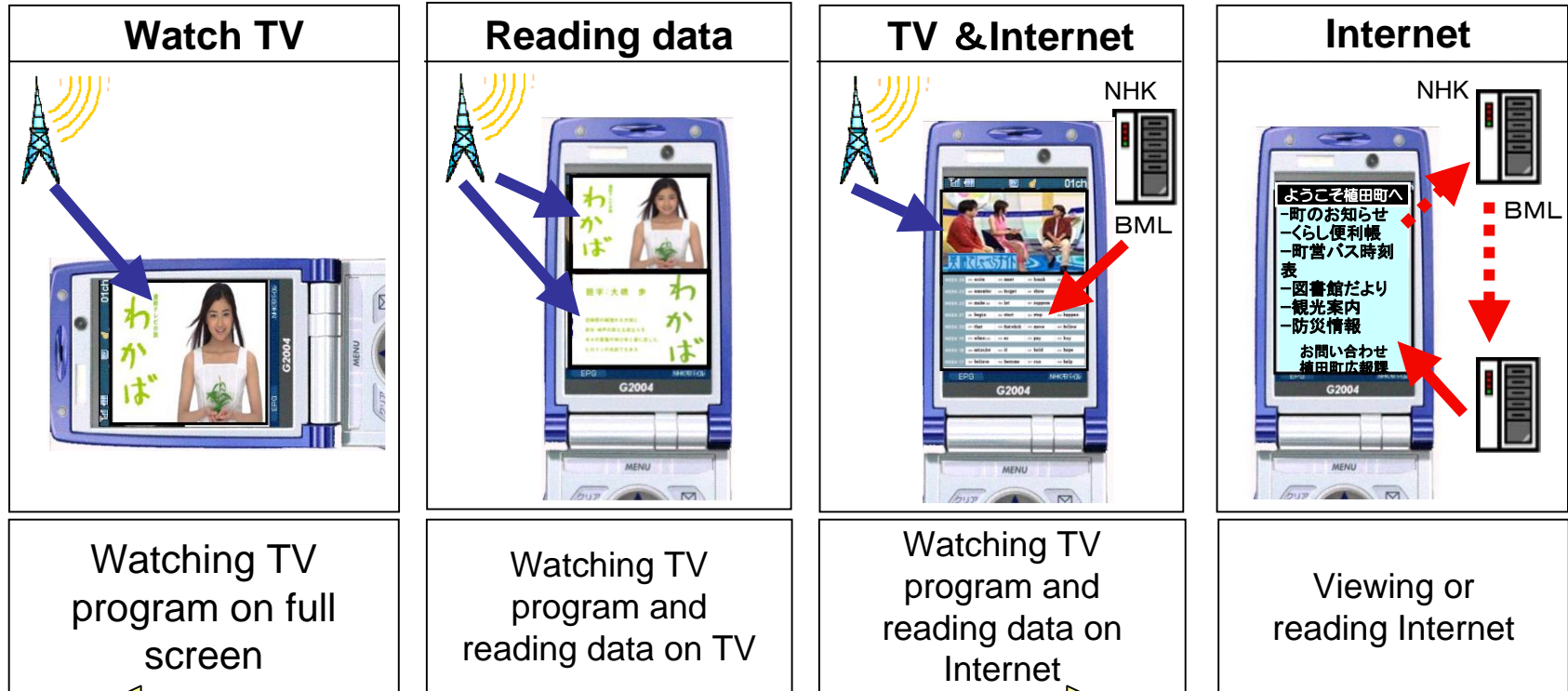



Line-up of DTTB Sets

Manuf.	Screen Size						
	10"	20"	30"	40"	50"	60"	70"
Toshiba		▲	●	●	▲		
Sharp	△	▲					▲
Sanyo	▲	▲	●	●	■		
Panasonic	△	▲	●	●	■		
Hitachi	△	▲	●	●	■		
Sony	△	▲	●	●	■		◆
JVC		▲		▲	■	◆	◆
Mitsubishi	△		▲	▲			
Pioneer					■	■	
Epson					◆	◆	
Nanao		▲	▲				

● CRT-TV
 ▲ LCD-TV
 ■ PDP-TV
 ◆ Rear PJ
 △ Analog LCD-TV

Price Distribution Map of DTV Sets

As of June 8, 2005

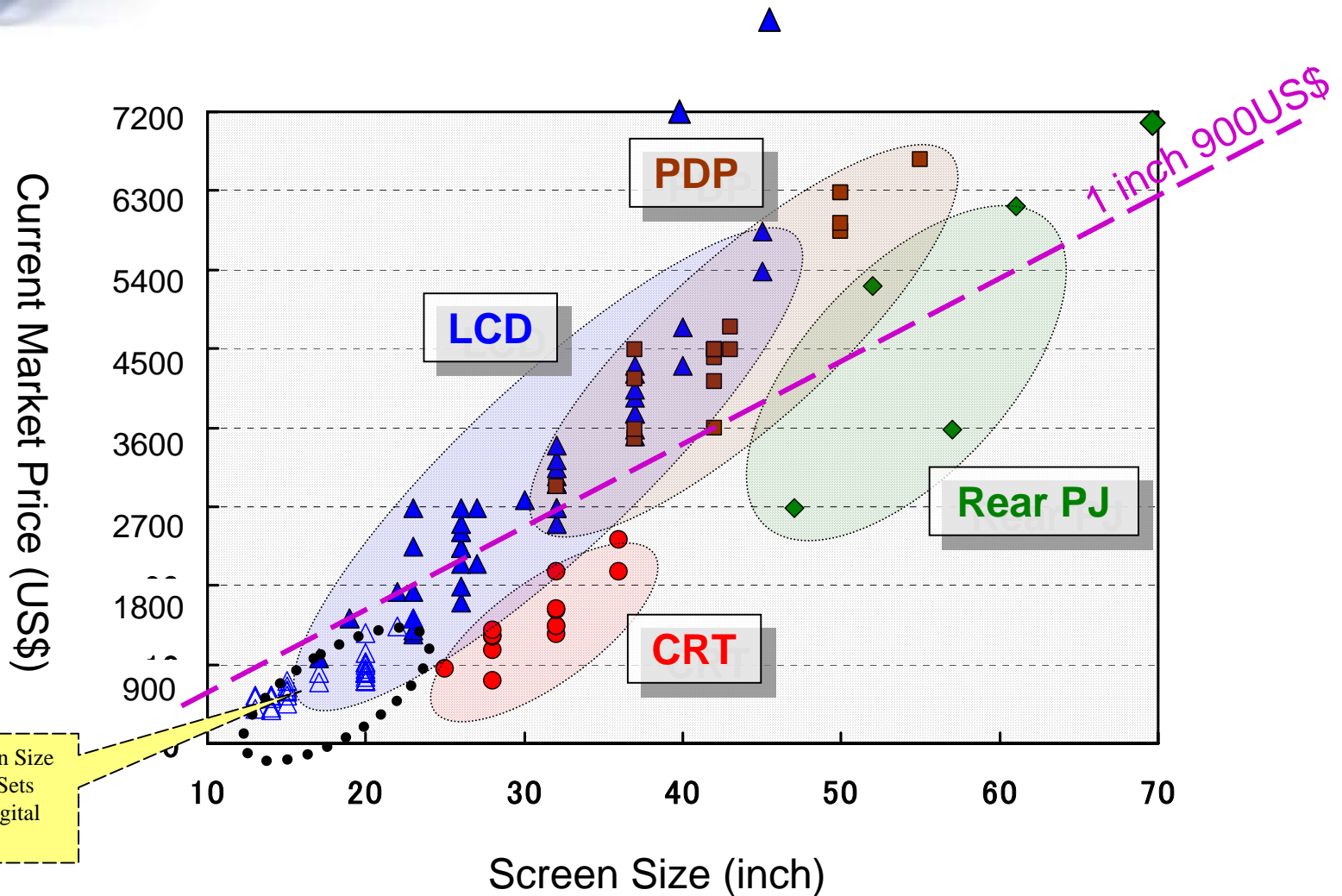

Shipment Volume of DTTB Receivers

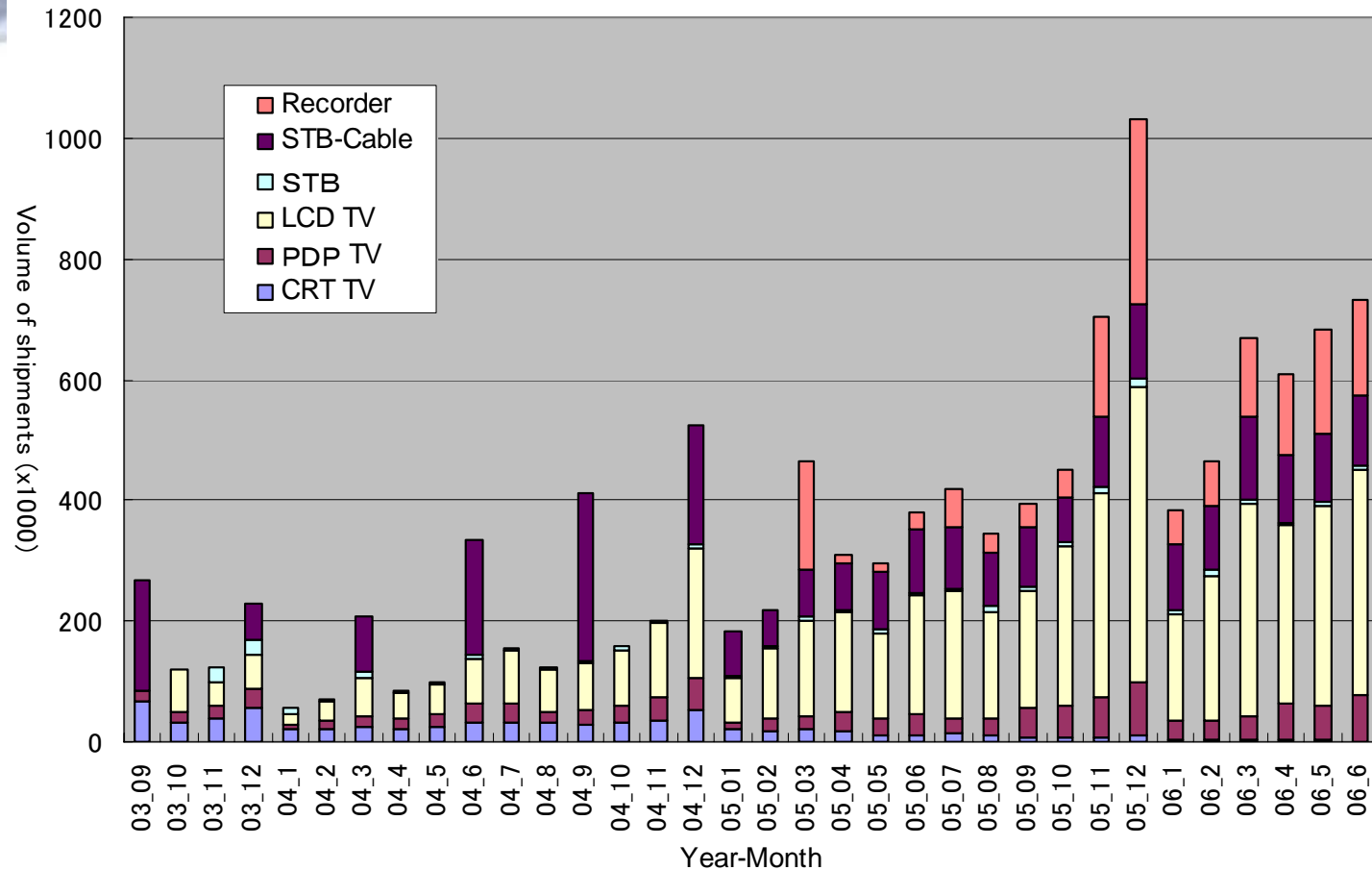

TV sets for mobile reception are not included the above graph.



The Cumulative shipments of DTTB Receivers

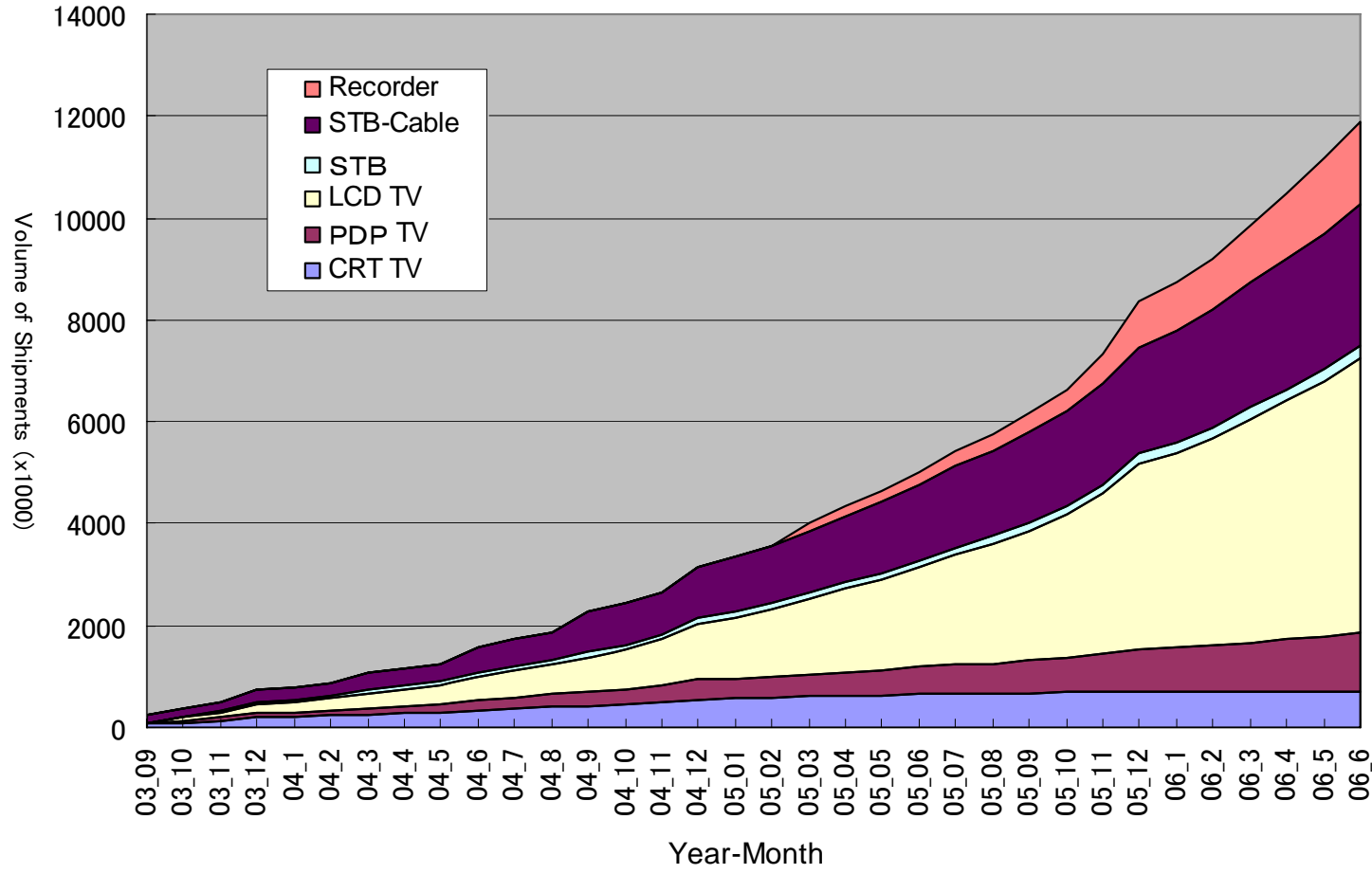

Targets on Diffusion and Shipment Volume of Digital Terrestrial TV Receivers

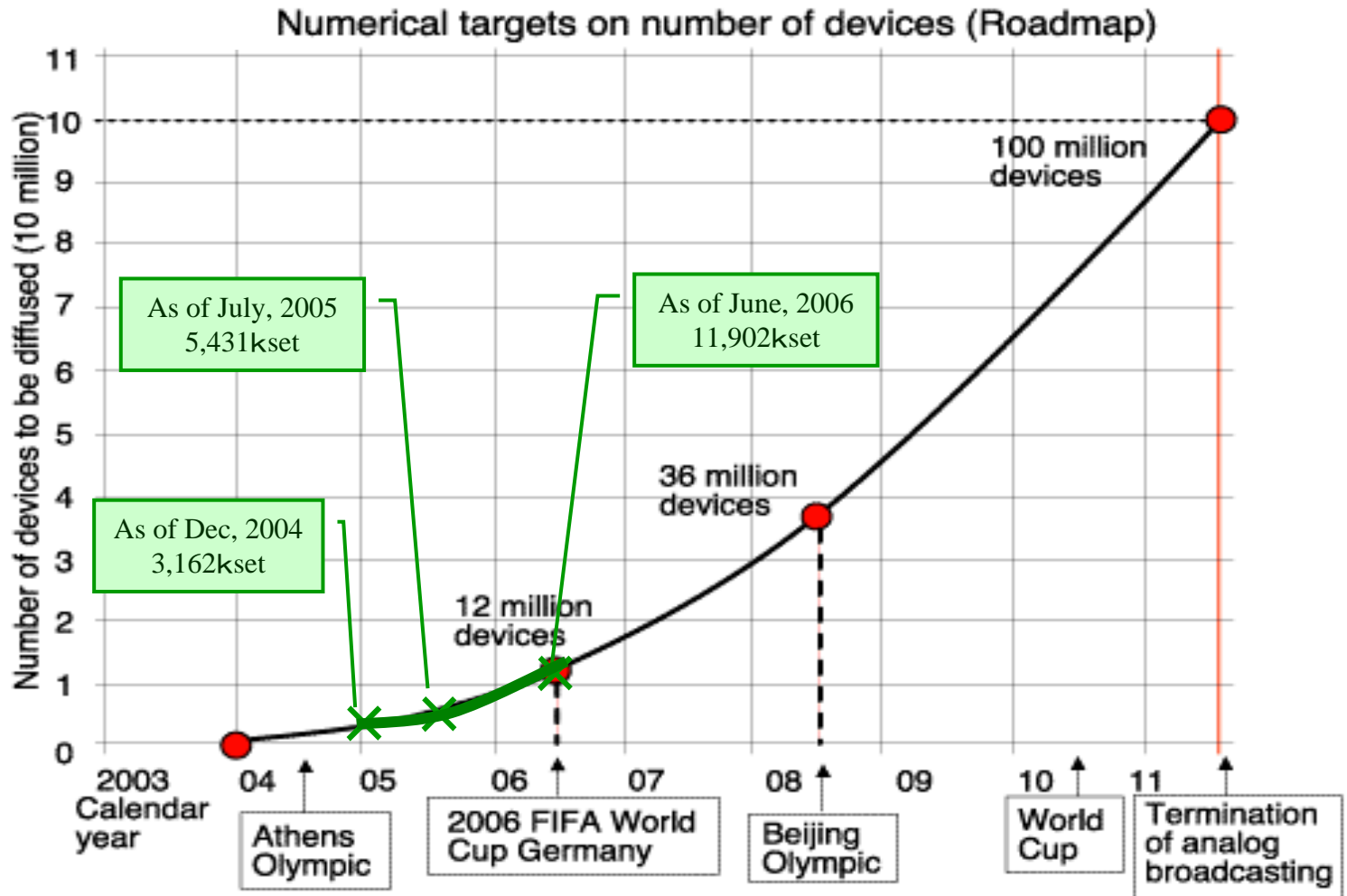



DTTB Products Now

- Extension of Receiver Model
- Examples of Receivers for each Model
 - Cellular Phone for One-seg Broadcasting
 - PCs with DTTB Tuner
 - DTTV receivers for Car-Navigation system
 - DVD Players and Audio Players
- Key Components and Parts for DTTB Receiver
 - Composition of DTTB Receiver
 - Examples of Chip set
 - Examples of Tuner

Examples of each companies products are shown in separate presentation

Expansion of DTTB Receiver Model

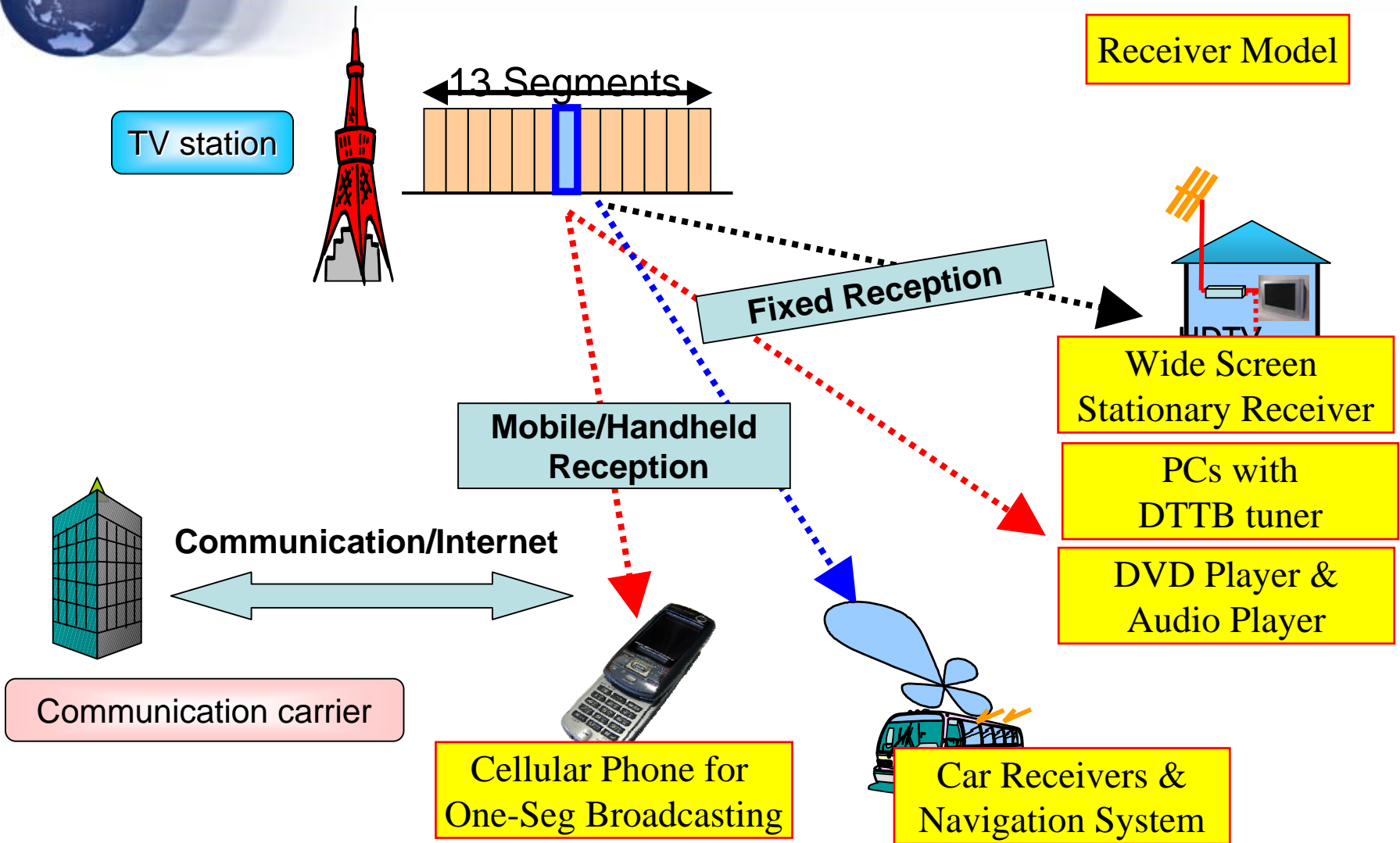

Cellular Phones for ONE-SEG Broadcasting



PCs with DTTB tuners

One-seg

SONY



※画像はVGN-TX92S

SONY



Tuner



FUJITSU



HITACHI
Inspire the Next



NEC



FUJITSU



FUJITSU

DTTV Receivers for Car-Navigation Systems

Tuners One-seg /12seg



Car-Navigation Systems with DTTB tuner



One-seg /12seg

SANYO
One-seg



One-seg /12seg



DVD Player and Audio Player

Portable DVD/SD/CD Player
with one-seg receiver



Panasonic

HDD Audio Player
with one-seg receiver



127 hours
programs
recordable

TOSHIBA

Hardware Constitution of Terrestrial/BS/CS Digital TV Receiver

(An Example of Panasonic receiver)

BS/CS Antenna

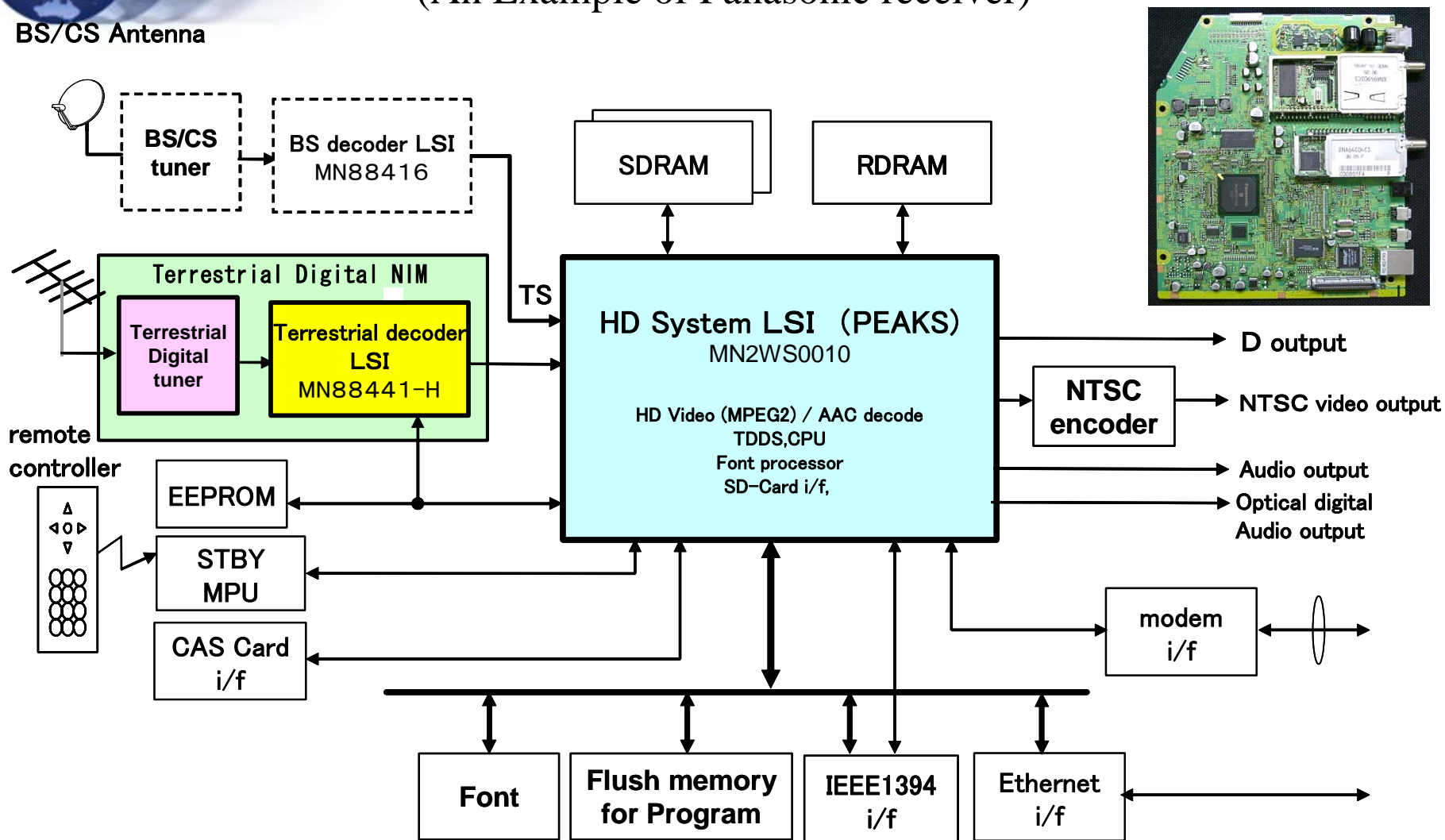



Obrigado

Thank you for your attention

Digital Broadcasting Expert Group (DiBEG)

<http://www.dibeg.org/>
mail; info@dibeg.org